

# IKA®

## Mixing and Processing Technology

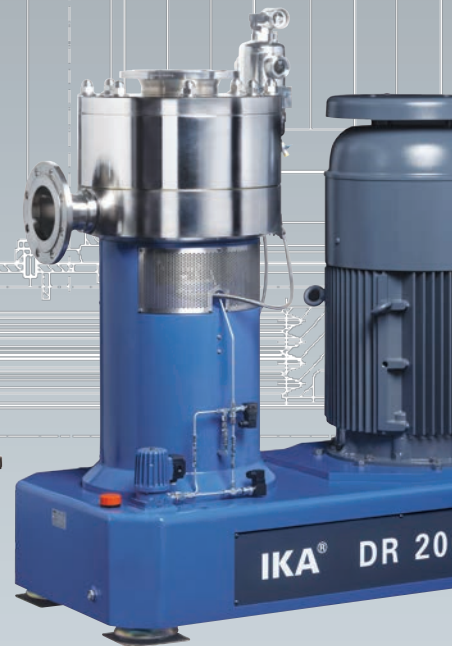
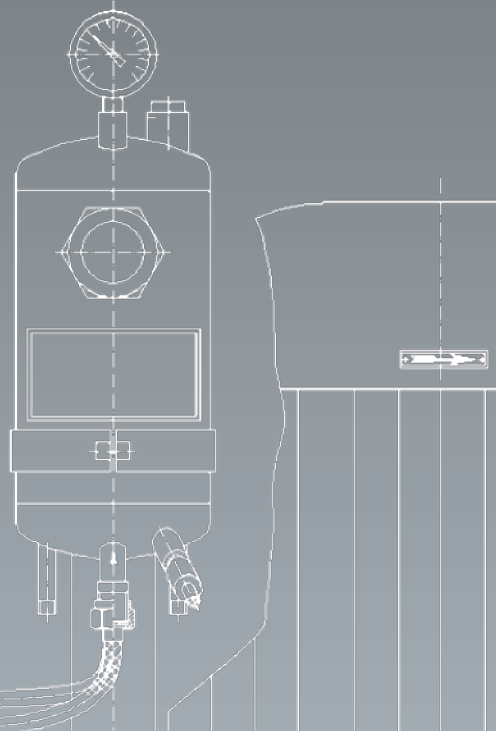
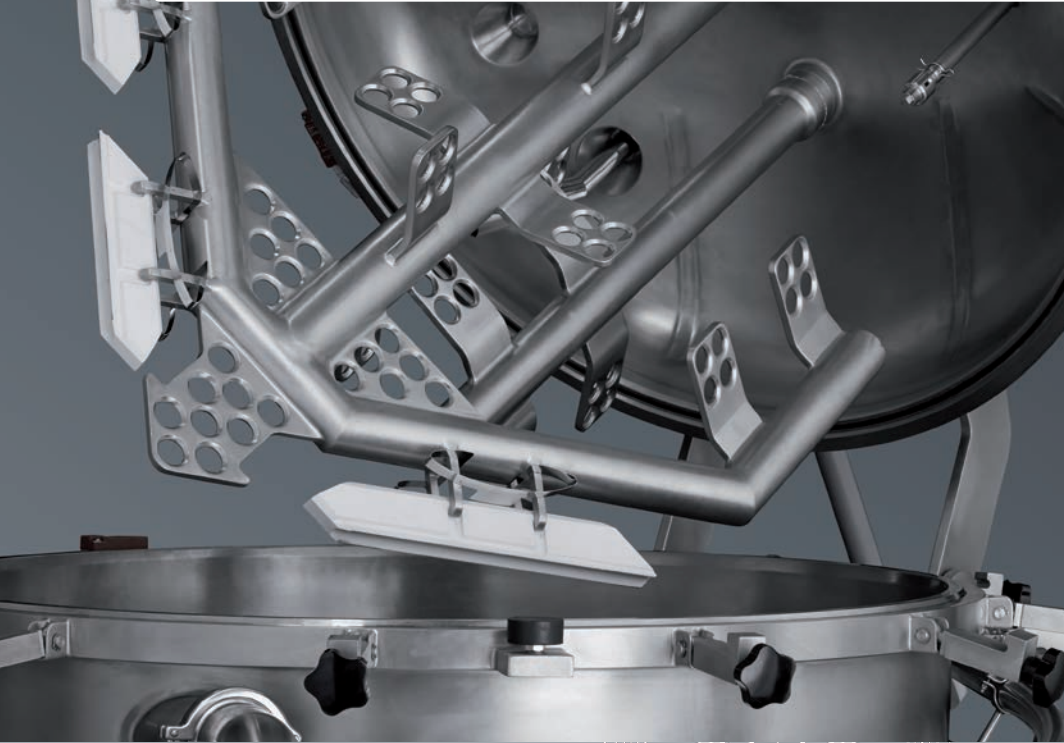

designed  
to work perfectly

**IKA®-Werke GmbH & Co. KG in Staufen, Germany can now look back on a century of history.**

The company which was founded in 1910 as a distributor for pharmacies and hospitals, was relocated from bombed-out Cologne to Staufen in 1942. There it quickly became the global market leader for laboratory technology as well as dispersing, stirring, and kneading machines. Today, IKA® employs over 800 people at eight different locations in four continents.

In the past decades the process equipment division of IKA® has attained a leading position in the mixing industry, as well as for engineered systems. This presence was established and strengthened by the IKA® innovative technology. Our high-quality stirring, mixing and kneading machines are widely used from the pharmaceutical to bitumen industry.



DIN EN ISO 9001



For more information please visit  
[www.ikaprocess.com](http://www.ikaprocess.com)



**Executed in IKA® quality**

Every IKA® product undergoes a final product quality test before it leaves our facility. An operational test and complete inspection ensures that every machine will be easily integrated at the customer's plant.



The machine program of IKA® is as diverse as the mixing industry itself. We specialize in solving the most difficult mixing applications for the processing industries.

In order to provide a solution for almost any mixing application, we have developed a series of machines. The IKA® 2000 series offers more options than any other in the mixing industry, including; wet milling, high shear dispersing, powder-liquid incorporation and more!

For batch and continuous processes, IKA® offers a complete line of high quality stirring, mixing and dispersing machines.

Continuous research and development, along with applying many years of experience, provides the basis for the IKA® philosophy.

Partnering with customers and research universities, IKA® is continuously developing new technologies and applications.



## Batch Mixing / Stirring

24

## Batch Dispersing

ROTOTRON

25

TURBOTRON

26

## Inline Mixing + Dispersing

ULTRA-TURRAX® Inline UTL 1000

9

ULTRA-TURRAX® Inline UTL 2000

11

DISPAX-REACTOR® DR 2000

12

DISPAX-REACTOR® DRS 2000

13

Colloid Mill MK 2000

14

Cone Mill MKO 2000

15

Corundum Disk Mill MCD 2000

16

Inline Disperser DBI 2000

17

Solid-Liquid-Mixer CMX 2000

18

Solid-Liquid-Mixer MHD 2000

19

## Systems and Plants

30

page

## Stands

28

# Innovation & Awards

It was a special honor for IKA® to receive the award shown on the right, confirming the unlimited use of the MHD 2000 in the chemical process technology. This machine has been developed for the inline and continuous mixing of solids into liquids.

Additionally, the Food and Drug Administration (FDA) awarded IKA® the 3A-sanitary approval for the complete new line of series 2000 machines. Another proof substantiating IKA® professional know-how.

Regular patent applications testify to the steady development, whereas ISO certification is securing the high quality standard.

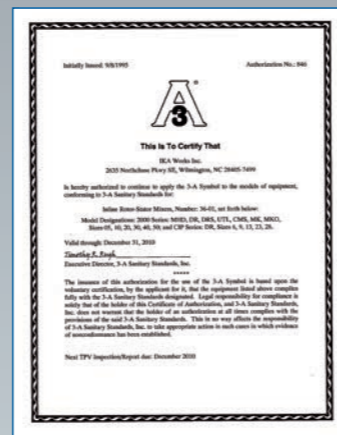

### IKA® magic LAB® 2000/03

The smallest MHD from the modular design series 2000. Equipped with the same tools and processing parameters as the industrial scale mixers, it is the ideal device for development of recipes, adaptation of processes, and of course for technical specification of production size machines. It should not be missing in any laboratory!

# Industries & Applications

## Industries:

- > Food
- > Chemical
- > Pharmaceutical & Bio-Technology
- > Personal Care & Toiletry
- > Household Products
- > Cosmetic
- > Paper & Pulp
- > Paints, Pigments and Coatings
- > Crop science
- > Petrochemical & Automotive
- > Energy, Waste Disposal & Recycling
- > Electronic
- > Bitumen

## Powder – Liquid Incorporation

- starches
- fumed silica
- milk solids
- cellulose
- sugar
- xanthan and guar gum
- carbopol
- pigments
- fillers
- pectin



## Wet Milling / Suspending – liquid / solid systems

- titanium dioxide
- pigments
- metals
- polishing agents
- seeds
- micro-encapsulations
- carbon black

- catalytic agents
- graphite
- clays
- sulfur
- crystals
- slurries
- API



## Homogenizing – concentrating particle size distribution

- flavors and essences
- creams
- coatings
- inks and lacquers
- fruit punches



## Emulsifying – liquid / liquid systems

- margarine
- ice cream
- proteins
- creams and lotions
- mayonnaise
- salad dressing and sauces
- micro-encapsulations

- paraffin
- cosmetics
- mineral oils
- silicon oils
- pesticides and herbicides
- waxes



## Dissolving – molecular / colloidal

- dyes
- crystal powders
- salts
- detergents
- sugar
- binding agents
- hydrocolloids
- elastomers
- resins
- thixotropic agents



## IKA+

In addition, IKA® high shear mixers have been proven in many other applications, such as;

- > Decomposing - organic tissue / plants
- > De-agglomeration / de-lumping
- > Precipitation - dehydration
- > Chemical reactions / gassing - O<sub>2</sub> / H<sub>2</sub>
- > Extracting - vortex extraction
- > Shred / Macerate / Crush / Pulverize

- tooth paste
- dressings
- cheese spreads
- jams
- spice concentrates

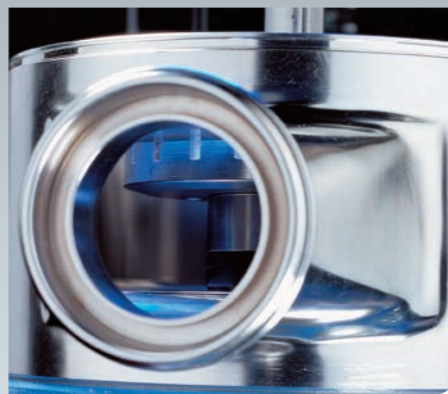

## ULTRA-TURRAX® Inline | UTL 1000

### Applications

- > Sauces
- > Fruit juices
- > Marmalades
- > Sugar solutions
- > Dyes
- > Binders
- > Molten resins
- > Lotions
- > Adhesives
- > Stabilizers

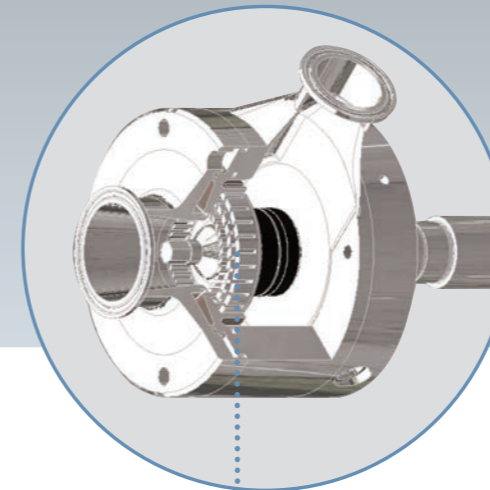

## Inline Dispersing Solid-Liquid Mixing

### The details make the difference!

A high quality belt drive, along with a premium efficient, inverter-duty motor provides an efficient and flexible drive system. Scalability is ensured by maintaining a constant shear rate on all machine sizes. A cartridge seal minimizes assembly and disassembly time, and offers optimum reliability.

IKA® uses high quality materials for exceptional mechanical strength and corrosion resistance. By working closely with our customers and research

institutions, the generators have been optimized for improved dispersing and efficiency. Generators are also available in many materials other than stainless steel for abrasive and corrosive applications. Some other key features are superior surface finishes, lack of dead spots, and designs that meet the stringent requirements of the FDA, EHEDG and 3A. IKA® Mixers can be cleaned or steamed in place. The 2000 Series has so many benefits, there are too many to list!

The economic ULTRA-TURRAX® UTL 1000 machines are used for homogenizing and dispersing (emulsifying/suspending) of pre-mixed liquid-liquid or solid-liquid substances.

The machine has a pump effect which can circulate the product up to a viscosity of about 1,000 mPas. For higher viscosities, the use of a feeding pump is recommended. The dispersing tool is exchangeable and can be adapted to many different process requirements.

The mixing chamber is mounted horizontally and the dispersing tool directly coupled to the motor shaft.

Type	Flow rate (max.) [l/h]	Motor power [kW]	Motor speed [rpm]
UTL 1000/10	5,500	7.5	3,000
UTL 1000/20	20,000	22	3,000
UTL 1000/30	40,000	37	1,500
UTL 1000/40	80,000	55	1,500
UTL 1000/50	125,000	110	1,500

# Series 2000 | Sophistication in the details

## Modular design – Provides better value and flexibility

### 2000 Series – Modular Design | A system with a great future!

As diverse as the mixing industry may be, there are many similarities from one machine to the next. IKA® has developed a new modular series of machines that takes advantage of these similarities. A basic drive unit can be fitted with a multitude of different machine heads, providing a solution for almost any mixing application. Our engineers, in cooperation with our customers, combined their expertise to develop the most innovative machine program in the industry!

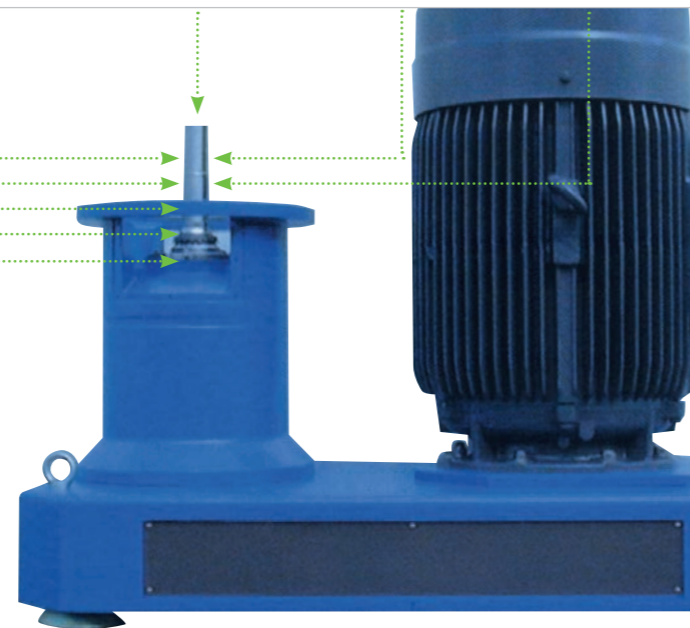
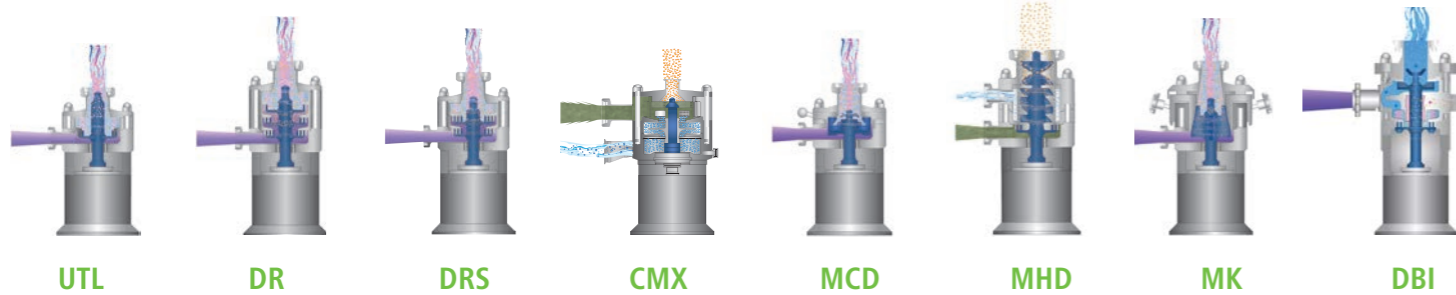

### Benefits of the 2000 series

- > Self draining due to vertical orientation
- > Dead spots are eliminated
- > Surface finishes meet FDA, 3A and EHEDG
- > CIP and SIP capable
- > Extensive mixing tool options
- > Low noise levels
- > Designed to meet food and pharmaceutical industry standards
- > Suitable for high pressure and temperature
- > Cartridge seal can convert into Single or Double mechanical
- > Directly Scaleable by maintaining constant tip speed

# ULTRA-TURRAX® Inline | UTL 2000

### Applications

- > Sauces
- > Binders
- > Fruit juices
- > Molten resins
- > Marmalades
- > Lotions
- > Sugar solutions
- > Adhesives
- > Dyes
- > Stabilizers



The UTL is a single stage dispersing machine used for the production of emulsions and suspensions requiring a coarse to medium particle size with a narrow distribution. A wide variety of rotor-stator combinations (generators) are available for adapting the machine to the application.

The UTL maintains a constant tip speed, regardless of machine size, ensuring scalability. A wide range of options is available on the motor, base, materials of construction, and more. The ULTRA-TURRAX® has high quality surface finishes for easy cleaning, and the machine is self-draining and CIP capable.

Type	Flow rate* [l/h]	Motor power [kW]	Motor speed [rpm]	Circumferential speed [m/s]
UTL 2000/03 (magic LAB®)	130	0.9	15,000	23
UTL 2000/04 (PROCESS/LABOR-Pilot)	300	1.5	3,000	23
UTL 2000/05	2,500	4	3,000	23
UTL 2000/10	8,000	7.5	3,000	23
UTL 2000/20	20,000	22	3,000	23
UTL 2000/30	40,000	37	1,500	23
UTL 2000/40	80,000	55	1,500	23
UTL 2000/50	125,000	110	1,500	23

\* Self pumping rate based on H<sub>2</sub>O and standard tool configuration

# DISPAX-REACTOR® Inline | DR 2000

## Applications

- > Creams
- > Lotions
- > Tooth paste
- > Fruit juices
- > Salt solutions
- > Catalysts
- > Lacquers
- > Polymer emulsions
- > Pesticides
- > Herbicides
- > Fungicides



The DISPAX-REACTOR® is a high shear, three stage dispersing machine for the production of micro-emulsions and very fine suspensions, for wet milling and deagglomeration of fine solid particles. Three rotor-stator combinations (generators) in a series produce a small droplet or particle size, with a very narrow distribution. The generators can be easily interchanged, offering the ultimate in flexibility. The DR line offers the same advantages as the UTL for scalability and sanitary design, and is CIP and SIP capable.

Generators available: Coarse, Medium, Fine, Superfine, 2P.

# DISPAX-REACTOR® Inline | DRS 2000

## Applications

- > Vaccines
- > API wet milling
- > Metal-oxide suspensions
- > Inks
- > Printing colors
- > Deagglomeration of pigments

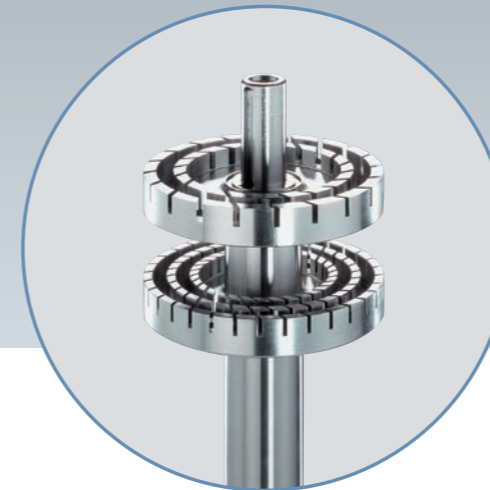

It is well known that tip speed, and therefore shear rate, is one of the most important factors in achieving the finest micro-emulsions. The SUPER DISPAX REACTOR® combines extremely high shear rates with a fine generator geometry to produce the ultimate in high energy dispersing.

Due to the high tip speeds, two stages are often all that is needed to achieve the results that are desired. The DRS is designed with the same high quality features as the UTL and the DR, and is especially suited for even the toughest pharmaceutical applications. The DRS can be an alternative to costly high pressure homogenizers.

Type	Flow rate* (max.) [l/h]	Motor power [kW]	Motor speed [rpm]	Circumferential speed [m/s]
DR 2000/03 (magic LAB®)	80	0.9	3,000	23
DR 2000/04 (PROCESS-Pilot)	500	1.5	3,000	23
DR 2000/05	2,500	7.5	3,000	23
DR 2000/10	10,000	15	3,000	23
DR 2000/20	20,000	37	3,000	23
DR 2000/30	40,000	55	1,500	23
DR 2000/40	80,000	75	1,500	23
DR 2000/50	125,000	160	1,500	23

\* Self pumping rate based on H<sub>2</sub>O and standard tool configuration

Type	Flow rate* (max.) [l/h]	Motor power [kW]	Motor speed [rpm]	Circumferential speed [m/s]
DRS 2000/03 (magic LAB®)	140	0.9	26,000	41
DRS 2000/04 (PROCESS-Pilot)	380	4	13,800	41
DRS 2000/05	700	5.5	3,000	40
DRS 2000/10	2,500	15	3,000	40
DRS 2000/20	7,000	37	3,000	40
DRS 2000/30	20,000	75	1,500	40
DRS 2000/50	40,000	200	1,500	40

\* Self pumping rate based on H<sub>2</sub>O and standard tool configuration

# Colloid Mill | MK 2000

## Applications

- > Colloidal solutions
- > Micro-suspensions
- > Incorporation of pigments
- > Metal-oxide suspensions
- > Micro encapsulation
- > Coating masses
- > Mustard
- > Mayonnaise
- > Ointments



The colloid mill MK 2000 is especially used for wet milling, deagglomeration and the production of viscous emulsions. The high tip speeds, combined with an extremely small shear gap, produces intense friction on the material being processed. The friction and shear that result is commonly referred to as wet milling. The rotor and stator are cone shaped, and have three stages of increasingly fine serrations, or grooves. The stator can be infinitely adjusted to obtain the desired gap setting between the rotor and stator.

The grooves change directions in each stage for increased turbulence. With high quality finishes and materials, the MK tool offers an extremely efficient milling geometry.

Type	Flow rate* (max.) [l/h]	Motor power [kW]	Motor speed [rpm]	Circumferential speed [m/s]
MK 2000/03 (magic LAB®)	200	0.9	3,000	23
MK 2000/04 (PROCESS-Pilot)	300	1.5	3,000	23
MK 2000/05	2,500	7.5	3,000	23
MK 2000/10	7,500	15	3,000	23
MK 2000/20	20,000	37	3,000	23
MK 2000/30	40,000	55	3,000	23
MK 2000/50	60,000	160	3,000	23

\* Self pumping rate with H<sub>2</sub>O, 0.1 mm shear gap and standard tool.

# Cone Mill | MKO 2000

## Applications

- > Pigments
- > Polymers
- > Coatings
- > Crystals, wet milling
- > Ceramics slurries

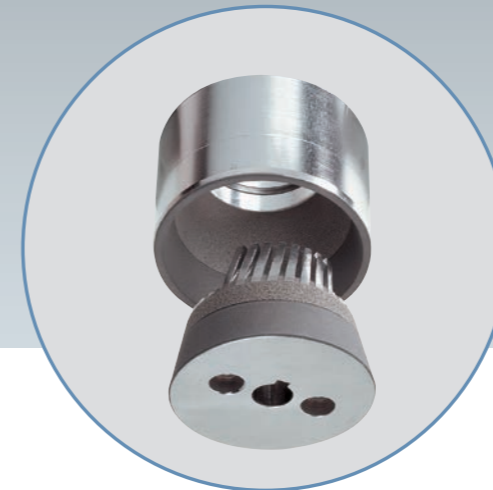

Another unique IKA® innovation, the cone mill MKO 2000 was designed to extend beyond the capabilities of the colloid mill. Given its innovative design, it is capable of wet milling and grinding, producing even smaller particle sizes than a colloid mill. The milling gap is infinitely adjustable so that exact amount of milling action can be obtained.

The surface of the milling tool is coated with an extremely hard coating that has a very rough surface texture. The coatings consist of high quality materials such as carbides and ceramics, and have different grain sizes. The milling tool produces an extremely intense shear zone that can process materials with high or low viscosities, but even finer distribution and particle sizes than a colloid mill.

Type	Flow rate* (max.) [l/h]	Motor power [kW]	Motor speed [rpm]	Circumferential speed [m/s]
MKO 2000/03 (magic LAB®)	25	0.9	3,000	23
MKO 2000/04 (PROCESS-Pilot)	100	1.5	3,000	23
MKO 2000/05	150	4	3,000	23
MKO 2000/10	500	15	3,000	23
MKO 2000/20	1,500	37	3,000	23
MKO 2000/30	3,000	55	1,500	23
MKO 2000/50	6,000	160	1,500	23

\* Typical flow rates for medium viscosity products at 0.1 mm shear gap



# Corundum Disk Mill | MCD 2000

## Applications

Fine milling of:

- > Mustard
- > Chili
- > Spice pastes
- > Nuts
- > Almonds
- > Sesame
- > Cocoa
- > Soy beans
- > Fruits
- > Vegetables
- > Fish pastes

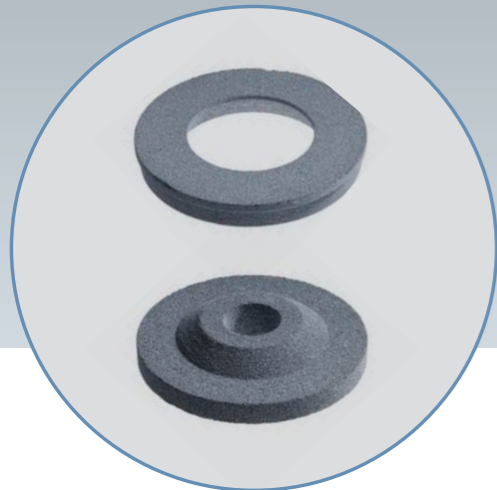

The Corundum Disk Mills are used for wet milling of granular, viscous and pasty products. The corundum disks are available with different grain according to the required fineness. The axially movable stator is pressed against the rotor which runs at high speed. Due to the high shear forces, the product is finely milled between rotor and stator and then discharged through the lateral outlet of the milling chamber.

A cooling jacket, integrated in the milling chamber, prevents an excessive heating of the product.

### Advantages

- > Feeding module with funnel and auger
- > Cooling jacket integrated in the housing
- > Precise and reproducible milling gap adjustment
- > Milling disks available in different grain sizes
- > Separate bearing of the drive shaft
- > Belt driven – vibration free and at low noise level
- > Low installation height

# Inline Dispenser | DBI 2000

## Applications

- > sunscreen
- > Beverages
- > Ointments
- > Mayonnaise, Dressings
- > Paints and lacquers
- > Starch solutions
- > Grease

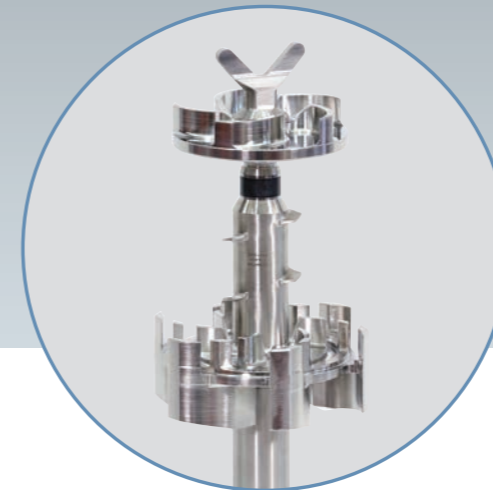

The high shear mixing and dispersing machine DBI 2000 is designed for the batch operation with a recirculating loop. It is directly flange-connected to the vessel outlet with a big cross section and pumps the product back into the vessel. Due to its wide inlet and the double stage design, it is suitable for processing low up to high viscous products. The DBI 2000 enables suction, pumping, dispersing and self-cleaning under CIP conditions.

This unique system combines high flow circulation, even particle size reduction and effective homogenization. Solid and liquid additives are fed directly into the dispersion chamber, which prevents lump formation and promotes rapid processing.

The DBI 2000 can also be integrated in an existing system or process to replace inefficient machinery.

### Advantages

- > Free selection pumping only or additional high shear dispersing
- > Direct feeding of solid and liquid additives
- > Effective dispersing with exchangeable tool designs
- > No additional pumps required for product circulation, CIP and discharge
- > The innovative design ensures shorter processing times and optimum dispersing quality

Type	Flow Rate [kg/h]	Motor power [kW]
MCD 2000/03 (magic LAB®)	1 – 20	0.9
MCD 2000/04 (PROCESS-PILOT)	5 – 100	2.2
MCD 2000/05	10 – 200	4
MCD 2000/10	25 – 500	7.5
MCD 2000/20	45 – 1,100	11
MCD 2000/30	125 – 2,500	37
MCD 2000/50	200 – 4,500	75

Type	Motor power [kW]	Max. total flow rate dispersing / pumping [l/h]	Max. viscosity final product [mPas]
DBI 2000/03 (magic LAB®)	0.9	max. 1,500	10,000
DBI 2000/04 (PROCESS-PILOT)	4	2,000 / 6,000	100,000
DBI 2000/05	7.5	5,000 / 15,000	100,000
DBI 2000/10	22	20,000 / 40,000	100,000
DBI 2000/20	45	45,000 / 80,000	100,000

## Powder incorporation in recirculation | CMX 2000

### Applications

- > Hydro colloids
  - > Alumina suspensions
  - > Starch solutions
  - > Calcium carbonate
  - > Milk powder
  - > Fumed Silica
  - > Carbopol
- All applications where large amounts of solids are incorporated into liquids

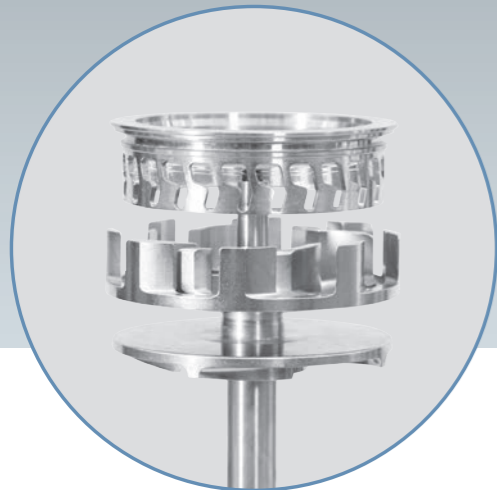

Incorporating powders into liquids, without lumps and without dust, is an important part of many processes. The CMX 2000 utilizes a specially designed rotor that creates enormous suction to draw in solids, while it pumps the liquid at the same time. The liquid can then be re-circulated until all powders are incorporated.

Additional dispersing can be accomplished by continually re-circulating without adding more powder. Dispersing can then be continued with closed powder inlet. Depending on the product respective the powder characteristics, high solids concentrations can be achieved.

Type	Motor power [kW]	Powder incorporation [kg/h]	Flow Rate (max.) [l/h]
CMX 2000/03 (magic LAB®)	0.9	250	1,500
CMX 2000/04 (PROCESS-Pilot)	4	1,300	5,000
CMX 2000/05	15	4,700	14,000
CMX 2000/10	30	8,900	32,000
CMX 2000/20	55	16,200	70,000
CMX 2000/30	110	25,500	110,000
CMX 2000/50	200	46,000	200,000

## Powder incorporation in a single pass processing | MHD 2000

### Applications

- > Fertilizers
- > Vitamins
- > Incorporation of color pigments
- > Pectines
- > Guar gum
- > Starches
- > Cellulose
- > Flour
- > Fillers

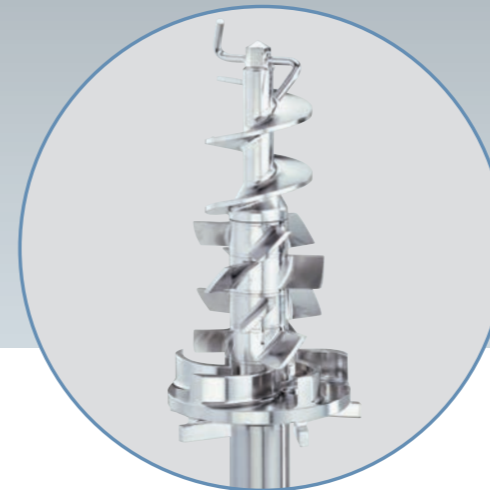

When production quantities require a continuous process, the MHD 2000 can get the job done. Solids and liquids are instantaneously mixed and dispersed in one step while maintaining a dust free environment. The MHD accurately combines the solid and liquid, and disperses them into a homogeneous, final product. Tanks and other auxiliary equipment can often be eliminated, saving capital and operating expenses. The MHD has a unique, patented design that doesn't require suction to draw in the powders, which essentially eliminates aeration. The MHD offers the greatest flexibility in production, and offers maximum product consistency. The MHD can also run in recirculation mode as an enrichment process. The MHD prevents bridging and aeration. Scalability is ensured by maintaining a constant tip speed of 23 m/s throughout the product range.

Type	Motor power [kW]	Total Flow Rate (max.) [l/h]	Max. solids capacity [l/h]
MHD 2000/03 (magic LAB®)	0.9	30	50
MHD 2000/04 (PROCESS-Pilot)	2.2	200	100
MHD 2000/05	5.5	700	500
MHD 2000/10	11	2,500	1,300
MHD 2000/20	15	7,000	2,800
MHD 2000/30	30	20,000	6,200
MHD 2000/50	75	40,000	11,200



## Dispersing / Stirring in a batch process

- > Various shaft seal types
- > Surfaces according to pharmaceutical requirements optional
- > Generators in various designs, increased shear rate and frequency

**ULTRA-TURRAX®  
UTC-KT  
(ambient)**

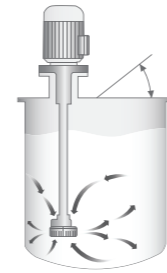

**ULTRA-TURRAX®  
UTC-KD  
(vacuum/pressure)**



**ULTRA-TURRAX®  
UTE  
(vacuum/pressure)**

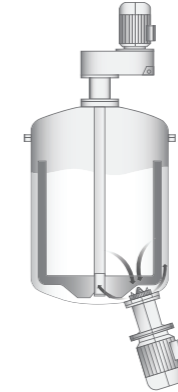

**Sealing type KD  
(mechanical seal)**

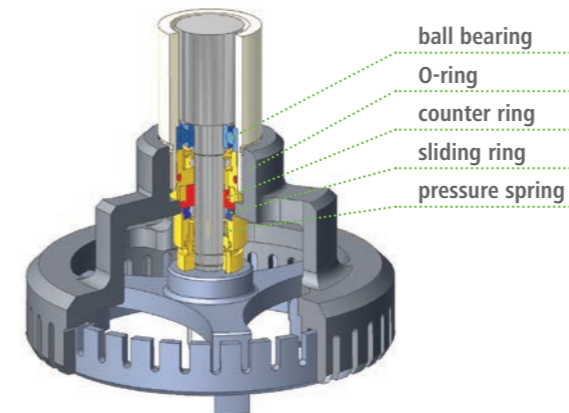

**Sealing type KT  
(lip seal)**

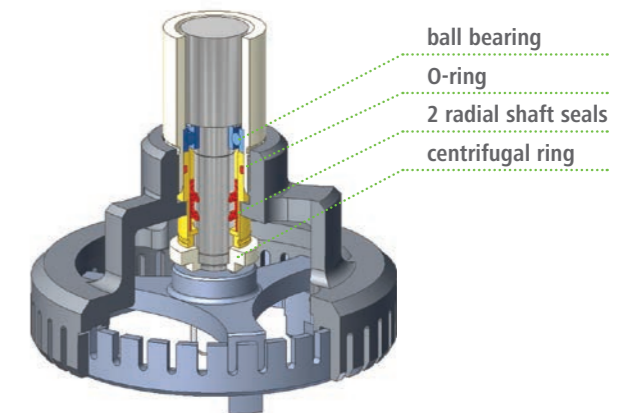

## Batch Dispersing

IKA® is the world leader in the design and manufacturing of high shear mixers and systems. IKA® produces a full range of mixers from laboratory to production scale. Our high shear mixers and dispersers feature our proven rotor-stator designs that are used in thousands of chemical, food, pharmaceutical and cosmetic companies.

The machines are designed to withstand the most demanding applications while providing the ultimate flexibility for your application needs.

**Rotor-Stator System**  
The best in dispersing technology

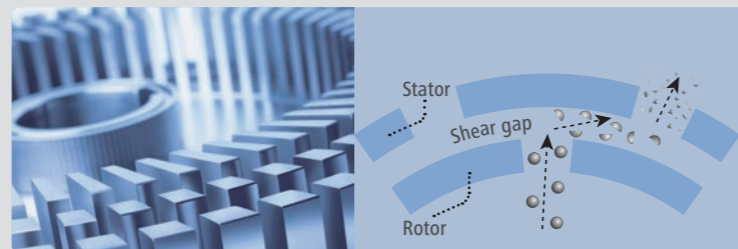

For several decades, the ULTRA-TURRAX® name has been synonymous with quality and reliability. The machines are used for the production of any kind of emulsions, suspensions and hydro-colloidal solutions. A variety of interchangeable generators (rotor + stator) enable further adaptations to the respective mixing task. Moreover, different types of seals allow different fitting positions as well as working under pressure up to 10 bar and with temperatures up to approx. 160 °C.

The models UTC, UTS and UTE are basically only differing in their peripheral design, the type of seal and assembly in the vessel. Nevertheless, the generators from these models are always the same so that the same mixing result is achieved. While the machine types UTC and UTS are for top entry assembly, the UTE is mounted on the vessel bottom. Therefore the UTE model is preferred in case of varying filling levels in the container.

# ULTRA TURRAX® | UTC / UTS - Top Entry

## Applications

- > Lotions
- > Waxes
- > Polishing agents
- > Gelling agents
- > Disperse dyes
- > Polymer emulsions

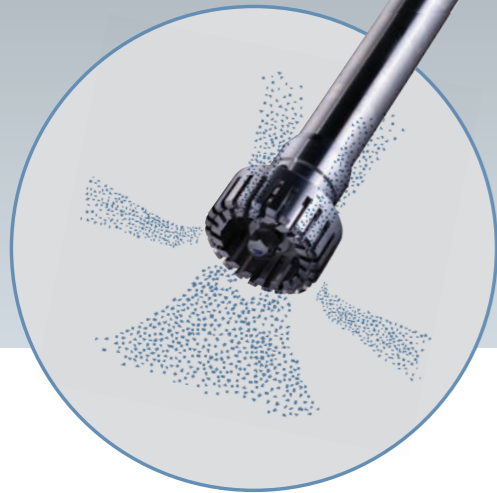

# ULTRA TURRAX® | UTE - Bottom Entry

## Applications

- > Lotions
- > Wax emulsions
- > Resin solutions
- > Gelling agents
- > Filter cake suspensions
- > Rubber solutions



## Advantages of the ULTRA-TURRAX® UTE:

- > Prevents aeration
- > Capable of operating under pressures of up to 16 bar
- > CIP and SIP capable
- > No shaft tube where material can stick on
- > Machine can run at very low liquid levels
- > Easy for cleaning
- > No bearings in the product

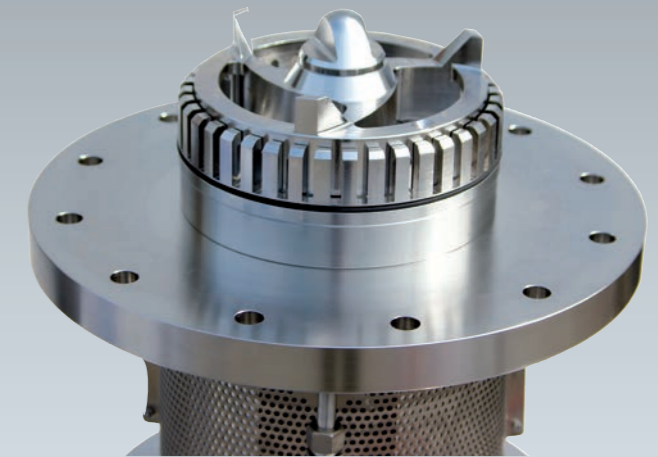

## High-shear Batch Mixers - bottom & side entry

The ULTRA-TURRAX® UTE for bottom or side mounting to vessels is, mainly used in case of varying filling levels and when strong spouts and air inclusions have to be avoided. Suitable for operation with pressures from 0.1 up to 16 bar and temperatures from -40 °C up to 160 °C.

Type	Batch size range* [l]	Rotational speed [rpm]	Circumferential speed** [m/s]	Motor power [kW]
UTC 80	30 – 150	3,000	10	1.5
UTC / UTS 115	100 – 500	3,000	15	3
UTC / UTS 150	350 – 1,700	3,000	21	7.5
UTC 220	500 – 2,500	1,500	15	11
UTC / UTS 280	750 – 3,500	1,500	20	18.5
UTC 300	800 – 4,000	1,500	21	30
UTC 330	1,000 – 5,000	1,000	15	22
UTC 350	1,200 – 6,000	1,000	17	32

\* Depending on the product viscosity. Regular range 1 – 5,000 mPas.

\*\* Higher Tip Speeds can be achieved with optional VFD Speed Controller on all UTC and UTS models.

Type	Batch size range* [l]	Circumferential speed** [m/s]	Motor power [kW]
UTE 60	20 – 70	23	1.85
UTE 115	80 – 400	15	2.5
UTE 150	150 – 750	21	5.5
UTE 220	250 – 1,200	15	11
UTE 280	500 – 2,500	20	22
UTE 300	800 – 4,000	21	30
UTE 450	10,000 – 25,000	30	160

\* Depending on the product viscosity. Regular range 1 – 5,000 mPas.

\*\* Higher Tip Speeds can be achieved with optional VFD Speed Controller on all UTC and UTS models.



# ROTOTRON® | RTS

## Applications

- > Food industry Ice cream, chocolate, flavorings, drinks
- > Paint and dye industry Inks, watercolors
- > Paper industry Adhesives, Pulp
- > Chemical industry Dyes, fertilizers, pesticides

## Advantages of the ROTOTRON® RTS:

- > Rapid mixing and dispersing results
- > Completely homogeneous mixing of the product in all areas of the container, even for critical shapes
- > Energy efficient
- > No rotation of the mixture, flow breakers are not required
- > Whirlpool effects and air inclusions are prevented
- > Flexible installation options in containers with a wide variety of shapes
- > No seal in the product
- > Exchangeable mixing heads available

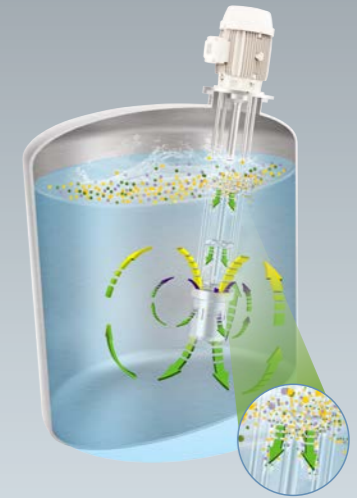

Optional Design

The IKA® ROTOTRON® RTS jet flow agitator is a universal overhead stirrer. RTS-type machines are used for homogenizing, dispersing, suspending, emulsifying, de-aeration and dissolving. The jet flow agitator is characterized by its high level of efficiency, intensively circulating and mixing products while consuming little energy.

The ROTOTRON® RTS is suitable for top entry and submerged mounting into large vessels. For many applications, it replaces the use of conventional agitators with extremely long shafts. The IKA® ROTOTRON® RTS can be used to process media up to a viscosity of 15,000 mPas. Depending on the application the rotary direction is changeable. In order to prevent sedimentation and floating ingredients, the flow direction is downwards. For the treatment of high viscosities and to avoid air incorporation, the turning direction can be changed, affecting an upwards flow.



## Batch Mixing/Stirring

Anchor Stirrer	Propeller Stirrer	Disk Stirrer	Turbine Stirrer	Toothed Disk Stirrer
$0.75 \leq \frac{D}{H} \leq 1$ $0.9 \leq \frac{d}{D} \leq 0.98$ $0.75 \leq \frac{h}{d} \leq 1$ $b = 0.1 \cdot d$	$0.5 \leq \frac{D}{H} \leq 0.75$ $0.1 \leq \frac{d}{D} \leq 0.5$ $\frac{D}{3} \leq a \leq \frac{D}{2}$ $B = 0.1 \cdot D$	$0.5 \leq \frac{D}{H} \leq 0.75$ $0.2 \leq \frac{d}{D} \leq 0.5$ $\frac{D}{3} \leq a \leq \frac{D}{2}$	$0.5 \leq \frac{D}{H} \leq 0.75$ $0.1 \leq \frac{d}{D} \leq 0.3$ $\frac{D}{3} \leq a \leq \frac{D}{2}$ $\alpha = 10^\circ$	$0.2 \leq \frac{d}{D} \leq 0.5$ $\frac{D}{3} \leq a \leq \frac{D}{2}$ $0.75 \leq \frac{D}{H} \leq 1$

	Anchor St	Propeller St	Disk St	Turbine St	Toothed Disk St
Circumferential speed [m/s]	0.5 – 1.5	3 – 10	3 – 7	2 – 12	10 – 25
Max. viscosity range [mPas]	50,000	5,000	10,000	8,000	50,000

Type	Batch size max. (H <sub>2</sub> O) [l]	Rotational speed [rpm]	Motor power [kW]
RTS 115	1,000	3,000	2.2
RTS 150	5,000	3,000	4
RTS 220	10,000	1,500	5.5
RTS 280	20,000	1,500	15

# TURBOTRON® | RF/RK

# TURBOTRON® | RFG/RKG

### Advantages of the TURBOTRON® machines:

- > Different drives are available for slow or variable speeds
- > Machines are suitable for ambient (RK) and pressure vessels (RF)
- > Optional frequency converters enable infinite speed adjustment
- > All wetted parts are stainless steel
- > Suitable for use in the food or pharmaceutical industry

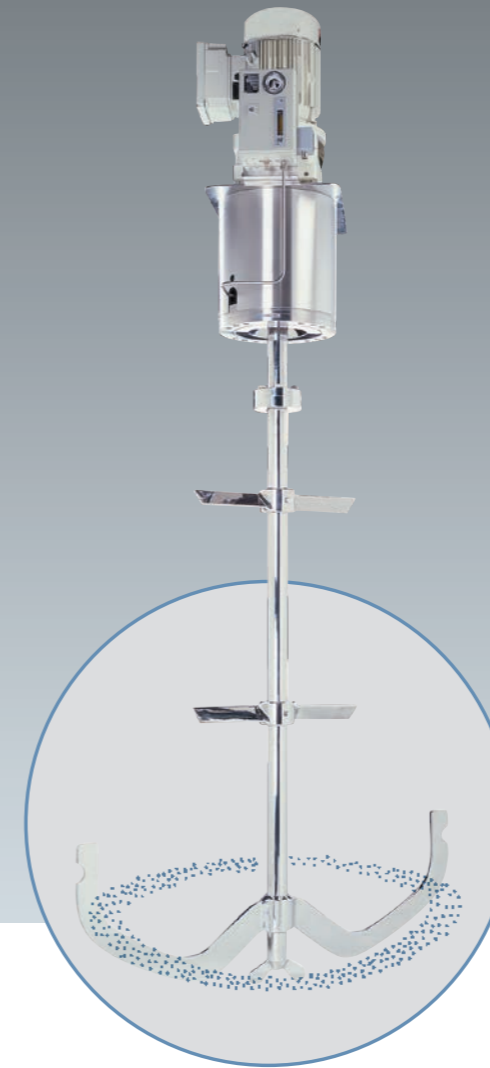
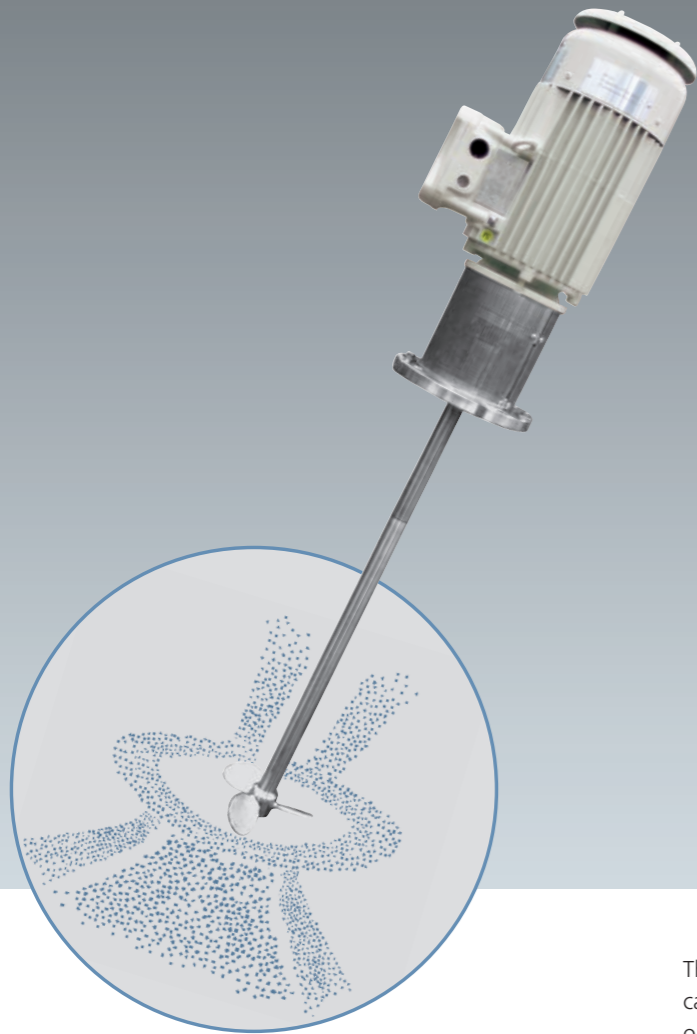

The name IKA® TURBOTRON represents the classic stirrer. The machine can be fitted with a wide variety of mixing tools. Motor, drive and seal options are available to fit the machine to the application.

While the RK is meant for operation in ambient condition, the TURBOTRON® RF can operate under vacuum or pressure and in a wide temperature range. Installation lengths can be specified according to the vessel size and the mixing tool is specified according to the processing target.

The regular viscosity range for the high speed agitations type RF/RK is up to approximately 1,000 mPas.

The RKG series is designed to be used with either open or closed vessels with ambient pressure. The agitator shaft is supported by an additional bearing in the flange. PTFE graphite material is used to seal the bearing, which provides excellent running properties and maximum resistance. Optional versions are available with mechanical seals.

The RFG models are designed for use with closed and pressure vessels (standard 2.5 bar) and are equipped with a massive lantern. Optional executions are suitable for full vacuum and/or pressures up to 10 bar. The agitator shaft is mounted in a gear box and can be equipped with an additional shaft coupling. The benefit of the models RKG/RFG is the suitability for viscous products and the possibility of long installation lengths.

Type	Batch size max. (H <sub>2</sub> O) [l]	Rotational speed [rpm]	Motor power [kW]	Installation length [mm]
RK / RF 00	500 / 1,000	1,000 / 1,500	0.37 / 0.55	800 / 1,500
RK / RF 01	1,000 / 2,000	1,500	0.55 / 0.75	1,000 / 1,500
RK / RF 02	1,500 / 3,000	1,000	0.75 / 1.5	1,000 / 1,750
RK / RF 03	2,000 / 4,000	1,000	1.1 / 2.2	1,250 / 1,500
RK / RF 04	2,500 / 5,000	750	1.5 / 3	1,500 / 1,500
RK / RF 05	3,000 / 6,000	750	2.2 / 4	1,750 / 1,750
RK / RF 06	3,500 / 8,000	1,000	3 / 5.5	1,750 / 1,750
RK / RF 07	4,000 / 12,000	1,000	4 / 7.4	1,750 / 2,000

Type	Batch size max. (H <sub>2</sub> O) [l]	Rotational speed [rpm]	Motor power [kW]	Installation length [mm]
RKG / RFG 00	1,000	250	0.55	1,250 / 1,500
RKG / RFG 01	1,500	250	0.75	1,250 / 1,500
RKG / RFG 02	3,000	250	1.5	1,500 / 1,500
RKG / RFG 03	4,000 / 6,000	250	2.2 / 3	1,500 / 1,750
RKG / RFG 04	5,000 / 8,000	250	3 / 4	1,750 / 2,000
RKG / RFG 05	6,000 / 12,000	250	4 / 5.5	2,000 / 2,500
RKG / RFG 06	8,000 / 15,000	250	5.5 / 7.5	2,000 / 2,750
RKG / RFG 07	12,000 / 20,000	250	7.4 / 9.2	2,000 / 3,000



## Stands

A complete line of stands are available for all IKA® stirrers and ULTRA-TURRAX® batch machines. Lifting and lowering can be done with either a manual hydraulic pump, or an electro-hydraulic pump for automatic operation. The stands may also be equipped with a swivel bracket for angle adjustment of the mixer.

An optional vessel clamp is also available. Other options are available, including materials of construction and electrical controls. The lifting height of the stand can be specified according to the requirements. Stainless steel versions with high quality surface finishes are available for the food and pharmaceutical industries.

## Stands



SFH 150

mobile stand with hydraulic hand pump



SFH 150 Stainless

mobile stand in stainless steel execution with hydraulic hand pump, control panel and vessel fixation device



SBAE 150

stand for floor mounting with lift adjustment by electric motor



SWAE 150

stand for wall mounting with lift adjustment by electric motor

Type of stand	Type of stand	Max. load [kg]	Max. lift height [mm]	Lift drive
SFH 150 / SFH 250	Mobile Stands	100 / 200	1,000	manual pump
SFAE 150 / SFAE 250		100 / 250	1,000	electric pump
SBH 150 / SBH 250	Floor Stands	100 / 250	1,200	manuarl pump
SBAE 150 / SBAE 250		100 / 250	1,200	electric pump
SWH 150 / SWH 250	Wall Stands	100 / 250	1,600	manual pump
SWAE 150 / SWAE 250		100 / 250	1,600	electric pump



# Systems and Plants

IKA® processing plants can be used for the production of solutions, emulsions and suspensions in many applications. Due to the advanced design, they can handle products that range from low viscosity up to pasty condition.

Flexible and easy to customize to the specific application, our plant systems can be used e. g. for cosmetic creams and lotions in the cosmetic and pharmaceutical industry, for mayonnaise or dressings in the food industry, for

suspensions and emulsions in the chemical industry as well as for production of paints and lacquers.

Based on our long experience with many applications IKA® is your competent partner for processing plants. In order to select the best configuration for your specific application, our test facility is staffed with experienced application engineers. It is equipped with a wide range of laboratory and pilot equipment to qualify the appropriate equipment to meet your application needs.

# Systems and Plants



### IKA® magic LAB®

The tiny, yet powerful laboratory dispersing machine, designed for mixing dispersing and wet milling. It can also be converted for batch operation with a 1 to 2 liter capacity.



### IKA® magic PLANT

The ideal small laboratory plant with a 2 liter vessel and an agitator for perfect mixing and homogenizing of liquids and pastes.



### Standard Production Plant

The approved "Standard Production Plant" SPP in an economic design is the IKA® solution for many fields of application. It is available in 8 sizes with capacities ranging from 25 to 4,000 liters.



### Master Plant

IKA® homogenizing and emulsifying system Master Plant allows for efficient mixing, dispersing, temperature control and additive feeding scaling from 10 to 4,000 liters. The innovative GMP-compliant mixing plant enables the processing of high viscosity products, especially in the food, cosmetic and pharmaceutical industries.



**IKA+**

**Scale-up**

Simplified scale-up by identical dispersing parameters for all sizes

## Develop – Optimize – Scale-up from laboratory to production scale

When new products are developed, the processes are initially tested in pilot plants. Small scale trials are also used to confirm changes in recipes or ingredients. Through the use of identical plant design and dispersion parameters, IKA® plant systems ensure a reliable scale-up with a constant product quality.



**IKA® pilots allow you to:**

- > Choose the process technology to be used
- > Define the required machine and system size
- > Establish the necessary energy requirements
- > Determine the required quality and volume of the raw materials
- > Calculate and define the quality standard of the final product
- > Determine the flow rate or batch times of the industrial system

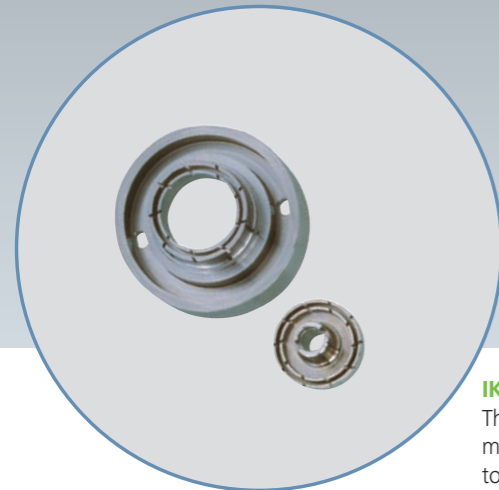

**IKA® magic LAB® 2000/03**

The magic LAB® is a modular laboratory mixing system that gives the user the ability to test a wide variety of applications on a laboratory scale. Using seven different, interchangeable mixing tools and variable speed control the entire scope of processing with rotor-stator systems can be tested.

Technical data	magic LAB® 2000/03	magic LAB® XP
Power supply [V]	1 phase, 220 – 240	3 phases, 380 – 420
Motor power [kW]	0.9	3
Temperature long / short time operation [°C]	80/120	120
Max. process vacuum/pressure [bar]	-0.5/2.5	-1/7
Standard rotational speed [rpm]	14,600	14,600
Adjustable rotational speed range	3,000 – 26,000*	see CONTROLLER
Circumferential speed [m/s]**	23	23
Flow capacity** [l/h]	100	100
Dimensions basic machine (W x D x H) [mm]	170 x 270 x 215	450 x 250 x 930
Weight basic machine [kg]	7	48
Dimensions transport box (W x D x H) [mm]	350 x 460 x 560	–
Weight basic machine in transport box [kg]	20	–

\* Incl. controller  
\*\* Speed 14,600 rpm, module UTL, 4 M, H<sub>2</sub>O

**IKA® magic LAB® XP**

The magic LAB® XP is an upgraded version of the standard magic LAB®, built to handle applications with one or more of the following requirements;

- > Higher pressure / high vacuum
- > Abrasive or non-lubricating products
- > High power requirements

Technical data	magic LAB® XP CONTROLLER
Power [kW]	3
Frequency range [Hz]	20 – 87
Rotational speed range [rpm]	3,000 – 23,500
Circumferential speed [m/s]	5 – 37

**IKA® LABOR-PILOT 2000/04**

Modular inline dispersing machine in pilot scale with upscale possibilities to the production scale. Drive with three phase asynchronous motor with V-belt drive.

Technical data	LABOR-PILOT 2000/04	PROCESS-PILOT 2000/04
Power supply [V]	3 phases 380 – 420	3 phases 380 – 420
Motor power [kW]	1.5	2.2
Max. admissible temperature [°C]	120	120
Max. process pressure/vacuum [bar]	3/-0.5	10/-1
Rotational speed [rpm]	8,050	8,050
Circumferential speed [m/s]	23	23
Flow capacity [l/h]*	500	500
Dimensions (W x D x H) [mm]	450 x 250 x 350	450 x 250 x 900
Weight [kg]	36	53

Technical data	LABOR-PILOT CONTROLLER	PROCESS-PILOT CONTROLLER
Power [kW]	2.2	4
Frequency range [Hz]	20 – 87	20 – 87
Rotational speed range [rpm]	3,170 – 13,789	3,170 – 13,789
Circumferential speed [m/s]	9.4 – 41	9.4 – 41

**IKA® PROCESS-PILOT 2000/04**

Inline dispersing machine in pilot scale; suitable for working under vacuum / pressure and at elevated temperatures. The machine is equipped with a double mechanical seal and lubrication system.



**Module ULTRA-TURRAX® UTL**  
Single-stage high shear mixer used for simple homogenizing tasks.



**Module DISPAX-REACTOR® DR**  
Three-stage disperser for manufacturing of the finest emulsions and suspensions and for the simulation of single pass processes.



**Module Colloid / Cone mill MK / MKO**  
Wet-milling using a milling tool with an adjustable gap. Emulsification (MK) and de-agglomeration (MKO) of viscous products.

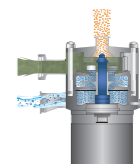

**Module CMX**  
Lump- and dust free processing of powders and granules



**Module MHD**  
Continuous inline proportional incorporation of powders into liquids in a one-pass operation.



**Module DBI**  
2-stage dispersing and pumping of solids and liquids to the dispersing chamber.

\* Standard speed, module UTL, 4 M, H<sub>2</sub>O

# magic PLANT | Exceptional – Flexible – Unique

IKA® introduces the next generation of laboratory scale processing plants. The perfect simulation of our batch mixing systems with smallest sample amounts.

The magic PLANT is the ideal laboratory scale process plant. It is specifically designed to test process and product conditions in an accurate small-scale simulation. Once a satisfactory product is obtained in the pilot scale, the next step is to transfer the manufacturing process to full-scale production. The magic PLANT system can be adapted to a wide range of applications and specific requirements especially in the food, cosmetic, chemical and pharmaceutical industries.



magic PLANT	
<b>Technical data</b>	
Useful volume [l]	2
Working pressure [bar]	-1 up to 2.5 (optionally 5 bar)
Max. temperature in the vessel [°C]	150
Dimensions (L x W x H) [mm]	430 x 520 x 670
Voltage [V]	1 x 230
Viscosity [mPas]*	1 – 100,000

Agitator	
<b>Technical data</b>	
Speed [rpm]	0 – 2,000 rpm
Stirring tools	> anchor > propeller > spiral agitator for drying > flow breaker
Motor power [W]	400

Disperser T 25 (optional)	
<b>Technical data</b>	
Motor power [W]	500
Speed [rpm]	3,400 – 24,000

\* Depending on execution and product properties.

## magic PLANT | The most versatile laboratory reactor

This system is used for batch mixing, homogenizing, emulsifying, suspending and for powder mixing and drying. The magic PLANT delivers a seamless process transition from product development to production in capacities of up to 2 liters.

## One machine | multiple applications

The IKA® magic PLANT is an extremely versatile and multi-functional process plant. Depending on the application, this unit can easily be modified into three different configurations.



magic PLANT basic

- > Adjustable speed drive for perfect agitating of pure liquids or suspensions
- > Tiltable, double jacketed and insulated vessel
- > Exchangeable stirring tools
- > Optional ULTRA-TURRAX® T 25 batch disperser
- > High pressure and full vacuum operation



magic PLANT inline

- > In combination with high shear inline disperser magic LAB® for high quality emulsions and suspensions
- > Pipe loop with manual 3-way valve for circulation or product discharge
- > Modular processing head for the simulation of various dispersing methods
- > Adjustable tip speed up to 40 m/s for smallest particle sizes



magic PLANT powder

- > Efficient and gentle mixing or drying of free flowing solids
- > Special powder agitator
- > Inclined working position for better mixing and drying results
- > Discharge by complete tilting of the vessel

**IKA+**

### Advantages

- > Modular design with exchangeable tools
- > Process simulation in smallest scale
- > Suitability for wet and dry products

# SPP | Cost-efficient Batch Mixing System

**IKA+**

The IKA® Standard Production Plant is a **state-of-the-art, yet cost-effective mixing system** for all basic mixing and dispersion technology operations.

The IKA® Standard Production Plant is available in **eight sizes** for volumes ranging from 25 up to 4,000 liters.

### Mixing Vessel

The unique conical shape of the vessel bottom enables complete discharge — even for highly viscous products.

### Recirculation Loop

Large pipe with 2-way flap valves and clamp connections

### Vessel Cover

The Standard Production Plant is equipped with a vessel cover tilting device. This enables the cover with agitator to open to a 90 degree angle.



### Funnel

for adding solid and liquid additives



# Technical data

**IKA+**

- > Small minimum capacity
- > Low installation height
- > Flexible configuration



Speed adjustment



Food Execution



Cleaning in Place



Pharma Execution



Sterilization in Place



Ex-protected



SPP 100



SPP 500

Standard Production Plant	SPP 25	SPP 50	SPP 100	SPP 250	SPP 500	SPP 1000	SPP 2000	SPP 4000
<b>Technical data</b>								
Total connected load [kW]	5	6	9	10	23	25	50	55
<b>Mixing vessel</b>								
Min. useable volume [l]	8	15	30	75	150	300	600	1,200
Max. useable volume [l]	25	50	100	250	500	1,000	2,000	4,000
<b>Dimensions (agitator)</b>								
Height (closed cover) [mm]	1,350	1,480	1,720	2,000	2,670	3,050	3,635	4,260
Height (open cover) [mm]	1,520	1,695	1,990	2,460	3,085	3,760	4,500	—
Width (open cover) [mm]	1,070	1,220	1,370	1,705	2,080	2,935	3,500	2,600
Depth [mm]	800	860	1,080	1,250	1,350	1,765	2,200	2,600

# Master Plant MP | Perfection in detail

**IKA+**

- > Counter-rotating agitator for highest viscosities, **inner agitator can be heated/cooled**
- > The complete plant can be **sterilized with steam (SIP)**
- > **CIP-cleaning**, for which the DBI 2000 serves as pump and feeds the rotating spray nozzles



### Connections

For vacuum, compressed air or funnel (additives)



### Alternative

Heatable or coolable spiral agitator

Opposing agitators with movable scrapers and a heatable or coolable inner agitator

### System Design

completely encased in stainless steel



### Dispersing Machine

The high-performance dispersing machine DBI ensures high quality, stable emulsions and suspensions.

### Human-machine-interface (HMI)

with touch-screen monitor

### Funnel

for incorporation of solids and liquids

# Technical data



Speed adjustment



Food Execution



Cleaning in Place



Pharma Execution



Sterilization in Place



Ex-protected

MP 10



MP 4000



Master Plant	MP 10	MP 25	MP 50	MP 100	MP 200	MP 500	MP 1000	MP 2000	MP 4000
<b>Technical data</b>									
Total connected load [kW]	5	7	8	12	13	31	35	70	80
<b>Mixing vessel [l]</b>									
Useful volume [l]	13	32	65	130	260	650	1,350	2,600	5,200
Working pressure in the vessel [bar]	-1 to 2.5	-1 to 2.5	-1 to 2.5	-1 to 2.5	-1 to 2.5	-1 to 2.5	-1 to 2.5	-1 to 2.5	-1 to 2.5
Max. temperature in the vessel [°C]	150	150	150	150	150	150	150	150	150
<b>Dimensions</b>									
Height (closed cover) [mm]	1,065	1,637	1,817	2,305	2,421	3,315	3,749	4,951	5,425
Height (open cover) [mm]	1,515	2,086	2,417	2,950	3,376	4,615	5,499	7,051	7,865
Width [mm]	635	850	850	1,215	1,215	1,650	1,650	2,210	2,210
Depth [mm]	661	1,010	1,010	1,407	1,407	1,900	1,900	2,710	2,710

IKA® offers more

Details can be found  
in our product brochures  
or online at  
[www.ikaprocess.com](http://www.ikaprocess.com)

### Vacuum Drying and Mixing



### Dry Milling

Impact and cutting mill for dry products | Pilotina  
Deagglomeration of solids | CONIKA



### Dilution Plants

For highly efficient and  
economical production



### IKA® Laboratory & Analytical Equipment

IKA® is the indisputable leader in the world market  
for laboratory technology. Numerous innovations  
are evidence of the growing momentum within the  
company.

Magnetic stirrers, agitators, dispersers, shakers,  
mills, rotary evaporators, calorimeters, temperature  
control instruments and laboratory reactors make  
up the laboratory and analytical technology product  
range.

### Kneading

Vertical, horizontal and continuous kneading



### High Pressure Homogenizer

For applications with particle size  
requirements in the nano range





### Qualification

IKA® machines and units are designed to be suitable for use in the pharmaceutical industry.

According to GMP guidelines, pharmaceutical companies are required to validate processes that influence product quality. The applied machines and plants are subjected to a severe qualification process. During this qualification it is tested and documented that the pre-specified functionality is achieved. As early as in the planning stages, IKA® machines and units are designed to be suitable for use in the pharmaceutical industry. IKA® will provide the necessary documentation and, if desired, will conduct the design, installation and operation qualification together with you.



### Services | First-rate quality from initial consultation to full scale production

From the initial planning stages to final product realization, IKA® technology and services is with you each step of the way by offering a multitude of services:

- > Designing complete production plants
- > Performing test runs when developing new products
- > Planning and implementation of mechanical, electrical and pneumatic installations
- > Commissioning, including a test processing and training the operating personnel
- > Qualification

After project completion, our experienced engineers, electricians, chemists, application technicians and assemblers will be available to assist you with:

- > Technical advice for questions concerning operation, process and maintenance of IKA® machines and plants
- > Spare parts service
- > Repair service
- > Modification
- > Upgrading



### Pilot Plant | From Idea to Solution

The IKA® pilot plant station consists of a vast array of different machines and plants as well as measuring and analytical devices. The pilot plant trials have influenced the concept and design of many of our machines and their tooling.

Searching for a suitable machine for your application? At IKA® pilot plant station you can test out several mixing systems with a variety of tools. Our chemical engineers look forward to assisting and advising you during and after the trials. This way, an optimal solution for your specific mixing task can be determined.

Subject to technical changes

**IKA®+**

**Learn more**

for further information on  
IKA® and IKA® products  
please visit our website

[www.ikaprocess.com](http://www.ikaprocess.com)

201609\_Process\_Technology\_IWS\_EN\_94000172



## IKA® Worldwide

### USA

IKA®-Works, Inc.  
Phone: +1 800 733-3037  
process@ikausa.com

### China

IKA® Works Guangzhou  
Phone: +86 20 8222 1771  
Sales-Proc@ika.cn

### Malaysia

IKA® Works (Asia) Sdn Bhd  
Phone: +60 3 6099-5666  
sales.process@ika.my

### India

IKA® India Private Limited  
Phone: +91 80 2625 3900  
process@ika.in

### Japan

IKA® Japan K.K.  
Phone: +81 6 6730 6781  
info@ika.ne.jp

### Brasil

IKA® do Brasil  
Phone: +55 19 3772-9600  
info@ika.net.br

### Korea

IKA® Korea. Ltd.  
Phone: +82 2 2136 6800  
info@ika.kr



[IKAworldwide](#) | [#lookattheblue](#)

IKA®-Werke GmbH & Co. KG  
Janke & Kunkel-Str. 10  
79219 Staufen  
Germany

Tel. +49 7633 831-0  
Fax +49 7633 831-907

process@ika.de  
www.ikaprocess.com